

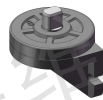









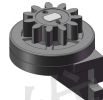

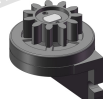
## 规格尺寸 Specification Size

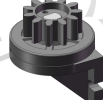
主体 Housing	GD-002	
齿轮 Gear		
G1	GD-002-G1	
	A 10.4mm B 8.8mm C 3.0mm D 7.5mm	
G2	GD-002-G2	
	A 10.4mm B 8.8mm C 3.6mm D 8.0mm	
G3	GD-002-G3	
	A 10.4mm B 8.8mm C 4.2mm D 8.6mm	
G4	GD-002-G4	
	A 12.0mm B 10.4mm C 3.0mm D 7.5mm	
G5	GD-002-G5	
	A 14.4mm B 12.8mm C 3.0mm D 7.5mm	
G6	GD-002-G6	
	A 14.4mm B 12.8mm C 4.4mm D 9.0mm	

## 齿轮参数 Gear Specification

型号 Part No.	G1	G2	G3	G4	G5	G6
类型 Type	标准平齿轮 Standard Spur Gear					
齿形 Teeth Profile	渐开线齿轮并齿 Involute Full Depth Gear					
模数 Module	0.8	0.8	0.8	0.8	0.8	0.8
压力角 Pressure Angle	20°	20°	20°	14.5°	20°	20°
齿数 Number of Teeth	11	11	11	13	16	16
基准节圆 Pitch Diameter	∅8.8	∅8.8	∅8.8	∅10.4	∅12.8	∅12.8

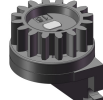
## 扭矩类型 Torque Type

型号 Part No.	扭矩 Torque (gf.cm/N.cm)	扭矩方向 Direction
GD-002-G*-20	20±5 / 0.2±0.05	双向 Both Directions
GD-002-G*-30	30±5 / 0.3±0.05	
GD-002-G*-50	50±8 / 0.5±0.08	
GD-002-G*-75	75±10 / 0.75±0.1	
GD-002-G*-90	90±10 / 0.9±0.1	
GD-002-G*-120	120±12 / 1.2±0.12	
GD-002-G*-150	150±15 / 1.5±0.15	
GD-002-G*-180	180±20 / 1.8±0.2	

## 材料 Materials

名称 Description	材质 Material
底座 Housing	PC/ABS
盖子 Cap	PC/ABS
转轴 Rotor	POM
齿轮 Gear	POM
油 Oil	硅油 Silicone oil

注①扭矩数据为20rpm,温度为23°C。  
Standard torque is decided at 20rpm and 23°C  
注②可以通过更换油的粘度提供特殊扭力定货。  
Within limits different torques can viscosity oil.

## 缓冲器耐久性 Damper Durability

\*最大使用回转速度 Max. Rotation Speed (rpm) 50  
\*最大使用频率 Max. Cycle Rate (cycles/min) 10  
\*使用温度范围 Operatin Temperature (°C) -30 ~ 80  
\*耐久使用 Durability  
50000次 (常温:23°C) 1循环=正转1.5圈 → 反转1.5圈 (90rpm)  
50000cycles (23°C ambient temperature)  
1 cycle = 1.5 revolutions forward (90rpm) 1.5 revolutions backward (90rpm)